

$\phi 6 \nabla 12$
M4 insert min. 8mm

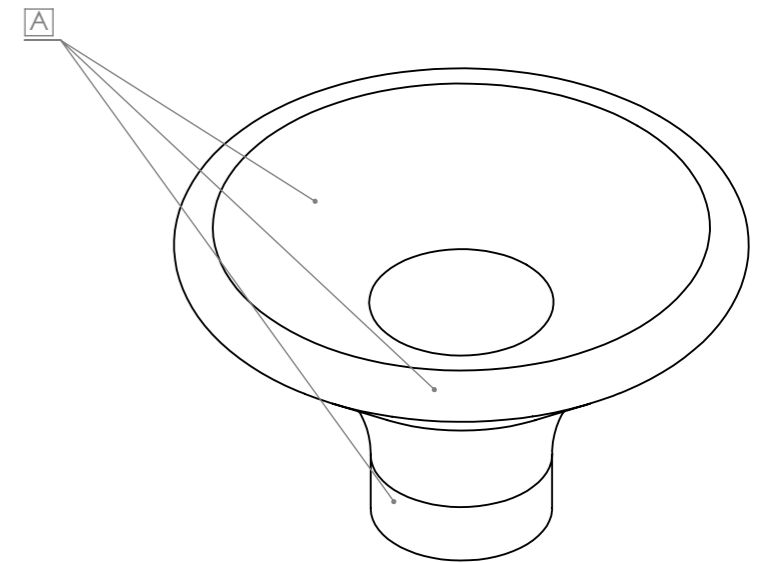

Rev.:	Date:	Name:	Description:

Part name: GRAPE	Projection: 	Sheet format: A3	Tolerance unless otherwise specified DS/ISO 2768-1M																										
	Sheet: 1 of 1	Scale: 2:1	<table border="1"> <tr> <td>Linear dimensions:</td> <td>0-3</td> <td>3-6</td> <td>6-30</td> <td>30-120</td> <td>120-400</td> <td>400-1000</td> <td>1000-2000</td> </tr> <tr> <td></td> <td>±0,1</td> <td>±0,1</td> <td>±0,2</td> <td>±0,3</td> <td>±0,5</td> <td>±0,8</td> <td>±1,2</td> </tr> <tr> <td>Angle:</td> <td colspan="2">±0,5°</td> <td colspan="2">Radius:</td> <td colspan="3">±5%</td> </tr> </table>				Linear dimensions:	0-3	3-6	6-30	30-120	120-400	400-1000	1000-2000		±0,1	±0,1	±0,2	±0,3	±0,5	±0,8	±1,2	Angle:	±0,5°		Radius:		±5%	
Linear dimensions:	0-3	3-6	6-30	30-120	120-400	400-1000	1000-2000																						
	±0,1	±0,1	±0,2	±0,3	±0,5	±0,8	±1,2																						
Angle:	±0,5°		Radius:		±5%																								
Designer:	Drawn by: NLS 14-02-24	Weight:	 Delta 2 Phone: +45 87 64 35 00 DK-8382 Hinnerup E-mail: fp@furnipart.com																										
Item no.:	109320038	Finish requirements (PS-004)																											
Material:	Aluminium/Zamac/Steel/Wood	[A] = Most important surface [B] = Important surface [C] = Less important surface	Requirements confer PS-001 Technical Specifications																										
COPYRIGHT: THIS DRAWING MAY NOT BE COPIED OR REPRODUCED IN ANY WAY WITHOUT DIRECT PERMISSION FROM FURNIPART A/S																													